

[306] GLUE-DOWN: CUT STAIR NOSING AND TACTILE STRIP

Disabled access rules DGUHC 2007-53 of 30 November 2007

Before laying the flooring, it is a good idea to inspect it and to identify any problems with the appearance. If there are visible defects, please notify GERFLOR and wait to hear from them before laying the flooring.

The stair nosing profiles are designed for the various step profiles that exist in buildings.
It is important to choose the correct profile for the stairs.
For example: protruding, sharp corner, rounded corner, etc.

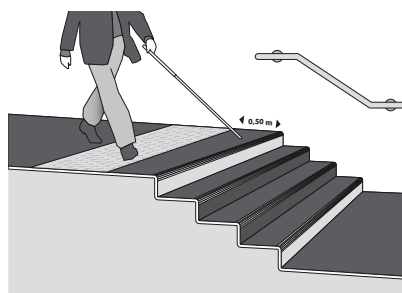
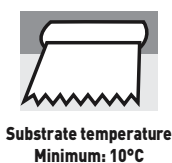

GLUING OF TREAD AND RISER

Do not use solvent based neoprene adhesive to glue down treads and risers. The material must be glued down using an **acrylic adhesive** with a coverage of 300 to 350 g/m² and applied with an A2 spatula (TKB standard). Follow the adhesive manufacturer's recommendations.

PVC STAIR NOSING

Glue down the stair nosing using a UZIN WK 222 **solvent free neoprene adhesive**.

1. INTRODUCTION

The stair nosing profiles are designed for the various step profiles that exist in buildings.

It is important to choose the correct profile for the stairs.

There must be a visual contrast between the stair nosings and the treads.

The stair nosings must be selected according to the tread configuration.

STAIR NOSING	REFERENCES
Sharp	0424, 0462, 0461, 0464
Protruding	0467
Rounded	0467
Aluminium	0503

STRAIGHT

Grooved stair nosing

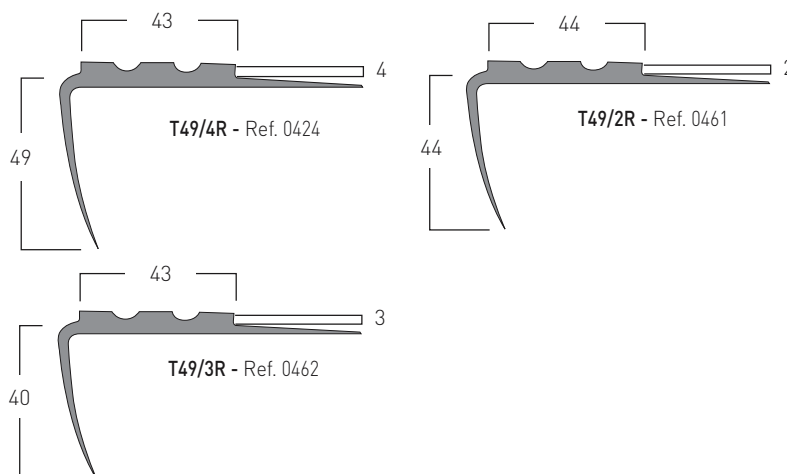
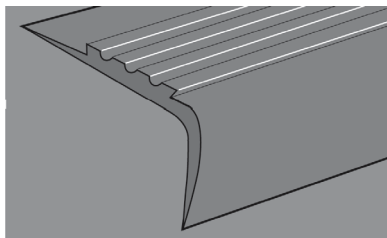

IMPORTANT: The information in these documents is valid from: 01/05/2019 and we reserve the right to make changes without notice. The technology is constantly evolving, so before carrying out any work, our customers should contact us to check that this document is still valid.

[306] GLUE-DOWN: CUT STAIR NOSING AND TACTILE STRIP

PROTRUDING OR ROUNDED STAIR NOSING

Grooved stair nosing

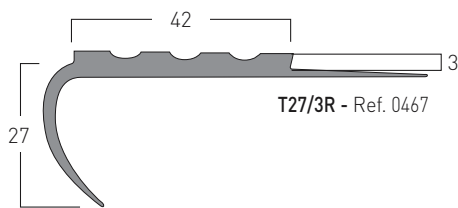
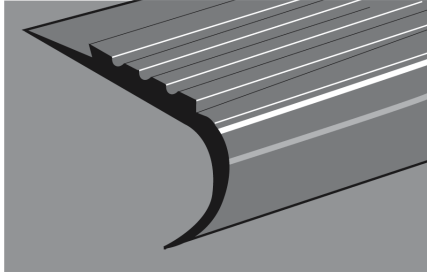

ALUMINIUM STAIR NOSING

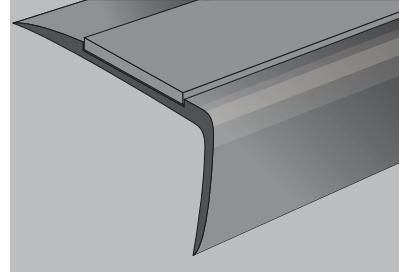

Use with a grey carbon strip provided

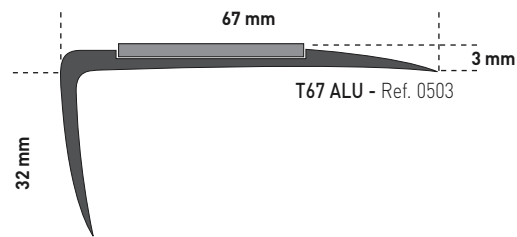

2. PREPARATION

2.1 - SUBSTRATE

The substrate should be flat, sound, smooth, clean and dry. The curve radius of the stair nosing must not exceed 12 mm. Carefully level the tread and the riser using a skimming compound that has been described in a technical report. A non-drip, thixotropic compound is recommended for the riser.

2.2 - STAIR NOSINGS

2.2.1 - Protruding stair nosing

Finish with a filler or a profile under the protruding part.

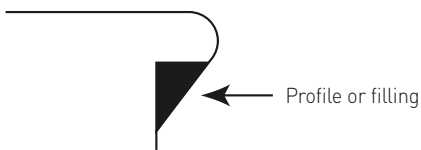

2.2.2 - Stair nosing with sharp corner

Do not change.

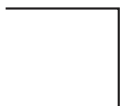

2.2.3 - Stair nosing with rounded corner

The curve radius must not exceed 12 mm.

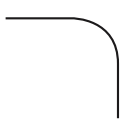

2.3 - PREPARING STAIRS

2.3.1 - Treads and risers

If the substrate is absorbent, apply a primer that is suitable for use with the particular adhesive.

2.3.2 - Back of tread (if finishing clips are used ref. H158)

Glue the base of the clip in the corner between the tread and the riser using an aqueous phase neoprene adhesive.

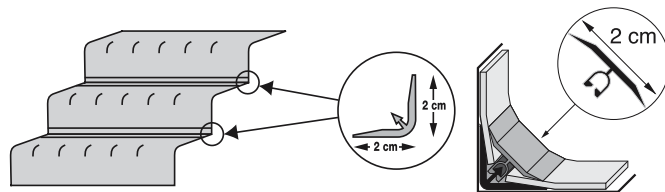

2.4 - LAYING FULL-WIDTH STEPS

Do not position the stair nosing before laying the riser using acrylic adhesive

2.4.1 - Prepare the full-width steps

2.4.1.1 - Cutting

• The treads and risers must be cut the day before, leaving 5 cm extra.

2.4.1.2 - Cut the stair nosings

The sections are cut to size. You are recommended to use high leverage nippers.

2.4.1.3 - Prepare the contrasting risers

Legal requirement:

The first and last step must have a riser at least 10 cm in height, which contrasts visually with the tread.

Gerflor supplies two products:

- Fitted strips using the same product in a different colour,
- Contrasting adhesive strips (see 5.2).

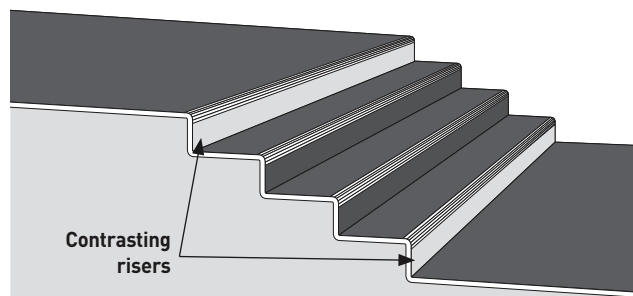

3. LAYING STEPS

3.1 - GLUING

Gerflor does not recommend using solvent based neoprene adhesive.

Follow these steps:

1. Apply acrylic adhesive to the riser with a coverage of 300 - 350g/m², A2 spatula (TKB standard).
2. Apply aqueous phase neoprene contact adhesive to the stair nosing. Do not apply adhesive to the vertical part of the profile.
3. Apply acrylic adhesive to the tread with a coverage of 300 - 350g/m², A2 spatula (TKB standard).

3.2 - LAYING THE STEPS

3.2.1 - PVC floor nosing

After the specified drying time, start laying at the bottom of the stairs.

- Position the riser and smooth it,
- Cut the floor covering at the edges,
- Position the stair nosing using the line you marked earlier.

DO NOT CUT THE TONGUE OF THE TREAD, which forms an integral part of the cut stair nosing.

- Smooth the stair nosing .

- Position the tread on the tongue, leaving a space of 1 mm between the floor covering and the stair nosing for welding.

- Smooth the tread.
- Cut the floor covering at the edges.

3.2.1.1 - Stair nosing/tread welding

- Open up the spacing if necessary.
- Use a triangle to create a bevel.
- Weld using CR40.
- Cut off the excess welding cord.

3.2.2 - Aluminium floor nosing

After the specified drying time, start laying at the bottom of the stairs.

- Position the riser and smooth it.
- Cut the floor covering at the edges.
- Position and smooth the tread.
- Cut the floor covering at the edges.
- Position the aluminium stair nosing, create holes and screw down.

4. JOIN WITH THE LANDING

Weldable PVC stair nosing:

The stair nosing and landing floor covering are joined by hot welding with a round cord CR40.

Aluminium stair nosing:

When the landing has been fitted, fix the aluminium stair nosing.

5. FINISHES

5.1 - BACK OF TREAD

5.1.1 - Step clip

- Insert the clip-on profile in the base by pressing down.

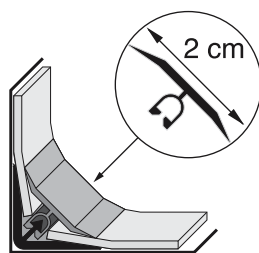

5.1.2 - Cold welding:

- See the diagram opposite.

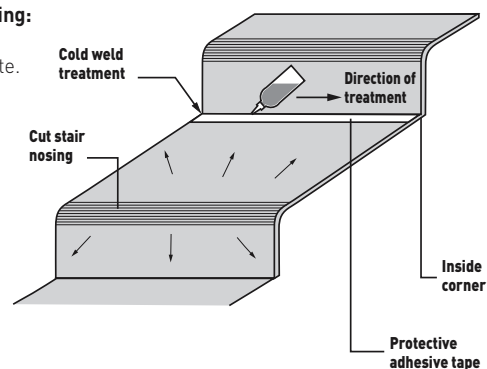

5.2 - CONTRASTING ADHESIVE STRIP ON THE RISERS

- Clean
- Pull off the protective film
- Apply the adhesive strip at the bottom of the riser
- Cut away the excess material

PRODUCTS	DIMENSIONS	GERFLOR CODE	REFERENCE
ADH. RISER 10 CM X 10 ML	10 cm x 10 m	058L	0001 White
ADH. RISER COUL10CMX10ML		058M	0003 Black 0005 Yellow

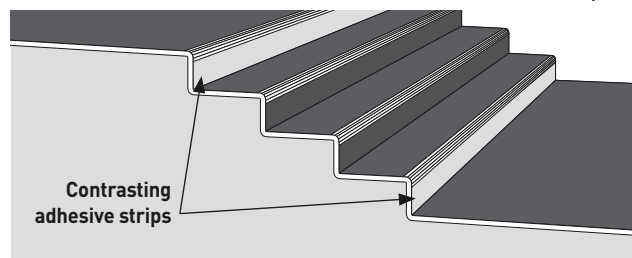

6. FIRST USE

12 to 24 hours after laying depending on the specified gluing method.

7. OTHER STAIRCASE TYPES

- Metal stairs with riser (rounded nosing). Strip fully, exposing the metal.

[306] GLUE-DOWN: CUT STAIR NOSING AND TACTILE STRIP

8. WARNING STRIPS

Legal requirement:

At the top of the stairs, the floor covering must create a visual and tactile contrast in order to provide a warning at a distance of 0.50 m from the first step.

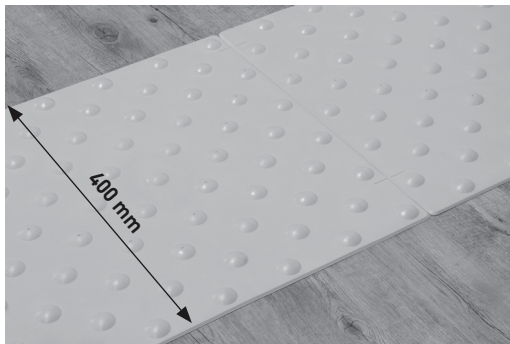
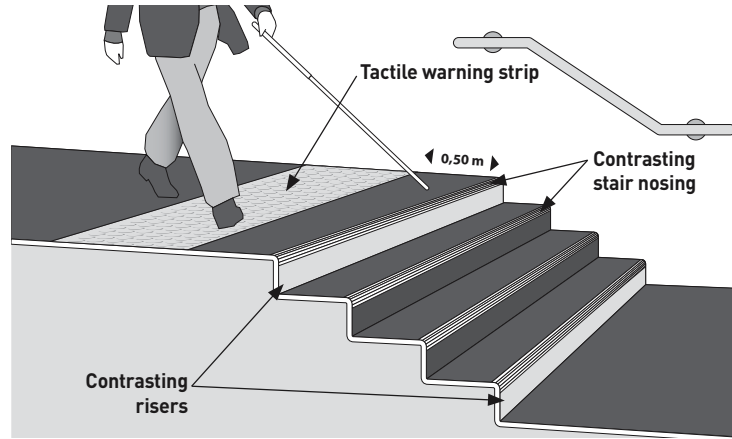

8.1 - SELF-ADHESIVE TACTILE STRIP:

1. Remove grease if necessary.
2. Mark a line 50 cm from the stair nosing.
3. Position the self-adhesive tactile strip, remembering the width of the strip – 400 mm.

Strip dimensions: 400/1350 mm - 815/400 mm.

PRODUCTS	DIMENSIONS	GERFLOR CODE	REFERENCE
TACTILE TILE 1350 x 400 - 4 UNITS	400 x 1350 mm	058F	0002 Grey 0003 Black - 0004 Orange
TACTILE TILE 815 x 400 - 10 UNITS	400 x 815 mm	058D	0002 Grey 0003 Black - 0004 Orange



8.2 - SELF-ADHESIVE TACTILE STUDS:

1. Remove grease if necessary.
2. Mark a line 50 cm from the stair nosing.
3. Position the template.
4. Install the studs using the template.

Strip dimensions:

One kit can create a strip of length 1350 and width 400 mm, or 200 studs.

PRODUCTS	DIMENSIONS	GERFLOR CODE	REFERENCE
TACTILE STUDS 200 UNITS	Diameter 25 x height 5 mm	058K	0002 Grey 0003 Black

Gerflor guarantees strips and tactile studs with the following floor coverings: Taralay Premium, Taralay Impression, Nera, Mipolam Homogènes and Taradal Confort. To check compatibility with other Gerflor products, please contact our technical department.



8.3 - INLAID TACTILE STRIP:

1. Mark a line 50 cm from the stair nosing.
2. Glue the warning strip in the same way as the floor covering of the landing.
3. Use scribing to cut the floor covering of the landing around this strip.
4. Bevel, hot weld and cut away the excess.

Dimensions of the inlaid strip: L: 1350 / W: 400 mm or L: 2000 / W: 400 mm

PRODUCTS	DIMENSIONS	GERFLOR CODE	REFERENCE
INLAID TACTILE STRIP 5 UNITS 2.00 x 0.4	2000 x 400 mm	L008	0005 Yellow 0007 Light grey 0009 Dark grey
INLAID TACTILE STRIP 5 UNITS 1.35 x 0.4	1350 x 400 mm	L009	0005 Yellow 0007 Light grey 0009 Dark grey